



2.4GHz GaAs Receive Front-End with LNA and Switch

Description

BHWM252 is a Receive Front-End IC in advanced GaAs E/D-PHEMT process that integrates a low noise amplifier and SPDT switch for optimal operation in the 2.4-2.5GHz frequency band. The device is internally matched to 50 Ohm all RF ports, and housed in an ultra-compact, 6-Lead DFN (Dual Flat No-Lead) package. It has integrated ESD protection circuits on all I/O ports.

Key Features

- Advanced GaAs E/D PHEMT Process
- 2.4-2.5GHz Operation Frequency Range
- Fully Matched RF Ports
- Tx Insertion Loss: 0.7dB
- Rx Gain: 13dB
- Noise Figure: 1.7dB
- LNA Current: ~10mA (Adjustable)
- Integrated ESD Protection for 600V HBM
- Ultra-Small 1.5x1.5mm DFN Package

Key Applications

- IEEE 802.11b/g/n/ac WLAN Systems
- Wi-Fi Modules
- IoT Modules including ZigBee/Thread/Matter
- Wireless Audio/Video
- Remote Control
- Generic 2.4GHz TDD Radio Designs

Functional Block and Package Information

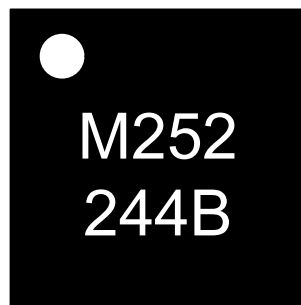
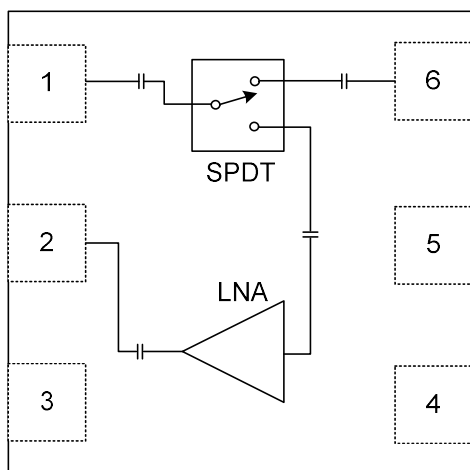

1.5x1.5x0.55mm 6L DFN



2.4GHz GaAs Receive Front-End with LNA and Switch

Pin Assignment and Pin Description

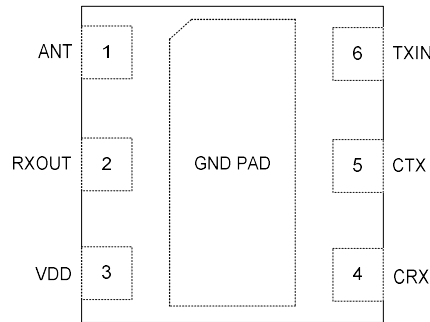

(Top "See-Through" View)

Pin Number	Pin Name	Description
1	Ant	Antenna Port
2	RXOUT	LNA Output
3	VDD	DC Supply Voltage for the LNA
4	CRX	Control Voltage for Rx Mode
5	CTX	Control Voltage for Tx Mode
6	TXIN	Tx Input to Antenna

Absolute Maximum Ratings

Parameter	Rating	Unit
Maximum Supply Voltage	5	V
Maximum Bias Voltage	3.6	V
Maximum Supply Current	100	mA
Maximum Input Power	+10	dBm
Junction Temperature	+150	°C
Operation Temperature	-40 to +85	°C
Storage Temperature	-40 to +150	°C
Moisture Sensitivity Level	MSL1	

Note: Do not exceed any single or combination of the above parameters. Sustained operation at or above the Absolute Maximum Ratings may result in permanent damage to the device. Maximum Input Power Rating assumes 50-Ohm load impedance.



2.4GHz GaAs Receive Front-End with LNA and Switch

Electrical Specifications: Receive (ANT to RXOUT)

Parameter	Condition	Specification			Unit
		Min.	Typ.	Max.	
Operating Frequency		2.4		2.5	GHz
Operating Voltage		1.5	3.3	3.6	V
Quiescent Current*	Vdd=CRX=3.3V, No RF Input		10		mA
Small-Signal Gain	Pin=-30dBm		13		dB
Shutdown Current	VDD=3.3V, CRX=0V		0.3		uA
Noise Figure			1.7		dB
Input P1dB	Vdd=3.3V		-1		dBm
IIP3	Vdd=3.3V		+6		dBm
Input Return Loss			10		dB
Output Return Loss			13		dB
Isolation			21		dB

*Quiescent Current can be reduced with an external resistor on the CRX control line.

Electrical Specifications: Transmit (TXIN to ANT)

Parameter	Condition	Specification			Unit
		Min.	Typ.	Max.	
Operating Frequency		2.4		2.5	GHz
Operating Voltage		1.5	3.3	3.6	V
Insertion Loss	Vdd=CTX=3.3V		0.7		dB
Input P1dB			25		dBm
Input Return Loss			10		dB
Output Return Loss			10		dB
Isolation			35		dB



2.4GHz GaAs Receive Front-End with LNA and Switch

Logic Control

CTX (Pin 5)	CRX (Pin 4)	Mode of Operation
0	0	All Off
1	0	Transmit
0	1	Receive

Application Schematic

(Refer to BHWM252 Application Note for Details)

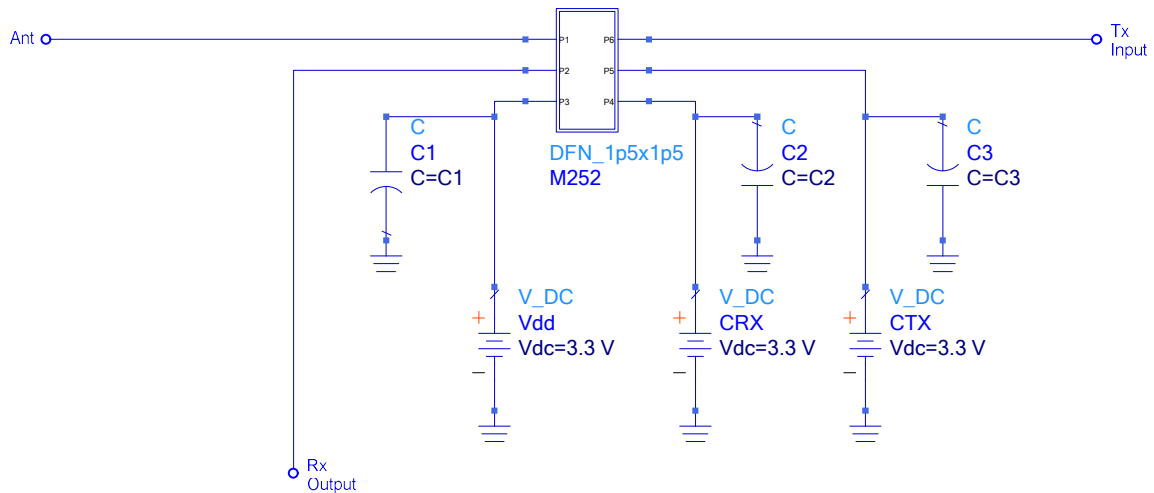



2.4GHz GaAs Receive Front-End with LNA and Switch

Package Drawing and Dimensions

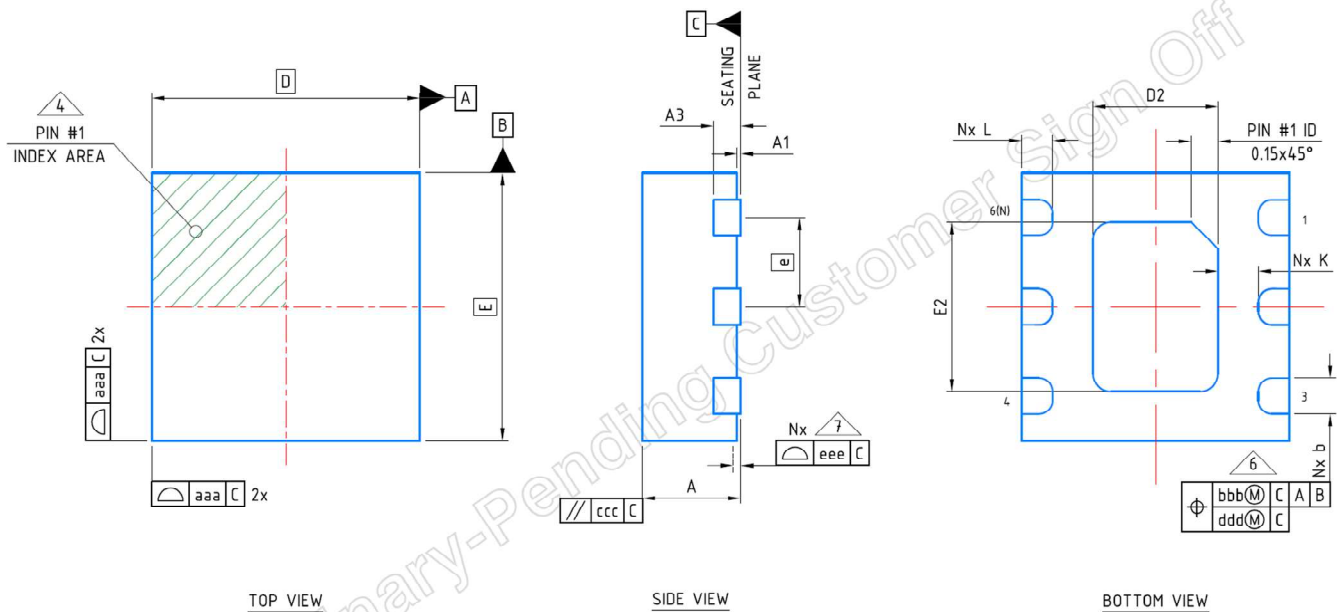

Dimension Table				NOTE
Thickness Symbol	UT			
	MINIMUM	NOMINAL	MAXIMUM	
A	0.51	0.55	0.60	
A1	0.00	0.02	0.05	
A3	---	0.15 Ref	---	
b	0.15	0.20	0.25	6
D	1.50 BSC			
E	1.50 BSC			
e	0.50 BSC			
D2	0.55	0.70	0.80	
E2	0.80	0.95	1.05	
K	0.15	---	---	
L	0.125	0.175	0.225	
aaa	0.05			
bbb	0.10			
ccc	0.10			
ddd	0.05			
eee	0.08			
N	6			3
NE	3			5
NOTES	1, 2			
LF PART NO.	443896			
LF DWG. NO.	CARSEM-HDS-043 Rev. A			

NOTE:

1. Dimensioning and tolerancing conform to ASME Y14.5-2009.
2. All dimensions are in millimeters.
3. N is the total number of terminals.
4. The location of the marked terminal #1 identifier is within the hatched area.
5. NE refers to the maximum number of terminals on E side.
6. Dimension b applies to the metalized terminal. If the terminal has a radius on the end of it, dimension b should not be measured in that radius area.
7. Coplanarity applies to the terminals and all other bottom surface metalization.



2.4GHz GaAs Receive Front-End with LNA and Switch

Package Marking



← Line 1: Pin 1 Indicator

← Line 2: Part Number, M252

← Line 3: Datecode, YWWB

Date Code Description

Y: Year Code (e.g, 2 for 2022)s

WW: Working Week (01~52)

B: Revision Code